

PERFORMANCE
MADE
SMARTER

产品手册

5334

二线制可编程变送器



温度 | 安全栅 | 通讯接口 | 多功能 | 隔离器 | 数显表

No. 5334V113-CN
序列号 : 212022169-232061652

PR
electronics

6 大特色产品

满足您的一切需求

单品出色·组合无敌

凭借创新型专利技术·信号调节更加简单·智能·产品组合由六大产品类组成·具备多种模拟量和数字量模块·涵盖上千种工业自动化应用·所有产品都符合甚至高于行业的最高标准·这可确保产品即便在最恶劣的环境条件下仍能可靠运行·5 年产品保修期·让您使用更安心·



Temperature

温度变送器和温度传感器系列产品·提供从温度测量点到系统控制一站式信号解决方案·从而在最大程度上保证信号的完整性·仅需一套点对点解决方案·您就可以在任何环境中将工业过程中的温度信号转换为模拟量信号·总线信号或数字通讯信号·该方案具备响应时间短·自动校准·传感器故障检测·低漂移和卓越 EMC 性能等诸多优点·



I.S. Interface

我们采用最严格的安全标准来检验产品·以期提供最安全的信号·秉承创新精神·我们已经在 SIL 2 全面评估本质安全型接口方面取得了开创性成就·其既高效又经济·效果卓著·成效斐然·模拟量和数字量本质安全栅种类齐全·同时提供多种输入输出·这使得 PR 标准成为一项易于实施的现场检验标准·在大型项目安装过程中·新背板方案大大简化安装和布线·且能与标准 DCS 系统无缝集成·



Communication

我们提供经济实惠·使用方便·面向未来的通讯接口·以便您能够访问所安装的 PR 产品·所有接口均可拆卸·并带有屏幕和按钮·可以显示过程值/诊断值和对参数进行配置·产品特定功能包括通过 Modbus 和蓝牙进行通讯·以及使用我们的 PR 过程主管 (PPS) 应用程序进行远程访问·适用于 iOS 和 Android 等终端·



Multifunction

单品为多功能系列产品·可涵盖大量现场应用·可轻而易举按照您的现场标准进行配置·此种单品可适用多种应用方式·既节省安装和培训时间·又大大简化库存备件管理·该设备专为长期信号精度高·功耗低·抗电噪声优异·编程简单而设计·



Isolation

基于微处理器技术研发的 6 mm 隔离器·小巧精致·响应迅速·品质一流·以极低的总拥有成本为专用应用提供卓越性能和抗电磁干扰·可水平或垂直安装·装置间无需间隙·



Display

数显表系列以其灵活性和稳定性著称·该设备系列几乎满足过程信号读数显示的所有需求·并具有通用的输入和供电能力·无论哪种行业·无论环境条件何其苛刻·该设备均能实时测量过程值并提供用户友好型界面和值得信赖的继电器信号·

二线制可编程变送器

5334

目录

应用.....	4
技术特点s.....	4
安装调试.....	4
应用.....	4
订购.....	5
电气规格.....	5
接线方式.....	8
方框图.....	8
设置参数.....	9
机械规格.....	9
传感器电缆的连接.....	9
ATEX 安装图 - 5334A.....	10
ATEX 安装图 - 5334B.....	12
IECEx Installation Drawing - 5334A.....	14
IECEx Installation Drawing - 5334B.....	16
INMETRO Installation Drawing - 5334A.....	18
INMETRO Installation Drawing - 5334B.....	19
文档更新记录.....	21

二线制可编程变送器 5334

- TC 信号输入
- 高测量精度
- 电气隔离
- 可设定传感器故障状态
- 标准 DIN B型传感器头部安装

应用

- TC 传感器线性化温度测量。
- 转换双极性 mV 信号转换为标准 4...20 mA 电流信号，并具备线性化表格输出功能。

技术特点s

- 参数设定简单方便。
- 内建温度传感器冷端补偿 (CJC)。
- 持续监测重要数据，保障使用安全。

安装调试

- 标准 DIN B型传感器头部安装。在非危险区域内，5334 可通过型号为 PR 8421 的配件安装在 DIN 导轨之上。

应用

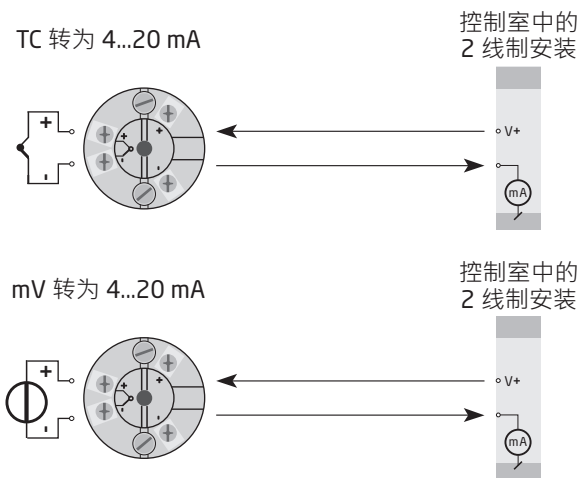

订购

型号	版本	环境温度	电气隔离
5334	Zone 2 / Div. 2 : A	-40°C...+85°C : 3	1500 VAC : B
	Zone 0 · 1 · 2 · 20 · 21 · 22 · M1 : B		

电气规格

环境条件:

工作温度	-40°C 至 +85°C
标定温度	20...28°C
湿度	< 95% RH (无冷凝)
防护等级 · 外壳/端子	IP68 / IP00

机械规格:

结构尺寸	Ø 44 x 20.2 mm
重量	50 g
最大导线规格	1 x 1.5 mm ² 绞线
螺丝端子力矩	0,4 Nm
抗振规格	IEC 60068-2-6
2...25 Hz	±1.6 mm
25...100 Hz	±4 g

常用规格:

电源电压 · DC	
5334A3B	7.2...35 VDC
5334B3B	7.2...30 VDC
内部功率耗散	
5331A3B	25 mW...0.8 W
5331D3B	25 mW...0.7 W
电压降	7.2 VDC
隔离电压 · 测试/工作	1.5 kVAC / 50 VAC
预热时间	5 分钟
上电后至稳定输出	4.5 s
设置参数	Loop Link
信噪比	最低 60 dB
响应时间 (可设定)	1...60 s
EEPROM 错误校验	< 3.5 s
信号动态范围 · 输入	18 位
信号动态范围 · 输出	16 位
电源电压变化的影响	< 0.005% 量程 / VDC

精度 · 一般值和基本值中较大的一个:

一般值		
输入类型	绝对精度	温度系数
所有	≤ ±0.05% 所设量程	≤ ±0.01% 所设量程/°C

基本值		
输入类型	基本精度	温度系数
电压	$\leq \pm 10 \mu\text{V}$	$\leq \pm 1 \mu\text{V} / ^\circ\text{C}$
TC 型号： E、J、K、L、N、T、U	$\leq \pm 1^\circ\text{C}$	$\leq \pm 0.05^\circ\text{C} / ^\circ\text{C}$
TC 型号： B、R、S、W3、W5、Lr	$\leq \pm 2^\circ\text{C}$	$\leq \pm 0.2^\circ\text{C} / ^\circ\text{C}$
EMC – 抗扰性影响 $< \pm 0.5\%$ 所设量程		
扩展的 EMC 电磁兼容： NAMUR NE 21, A criterion, burst. $< \pm 1\%$ 所设量程		

电气规格·输入：

TC 输入：

型号	最低温度	最高温度	最小量程	标准
B	+400°C	+1820°C	100°C	IEC584
E	-100°C	+1000°C	50°C	IEC584
J	-100°C	+1200°C	50°C	IEC584
K	-180°C	+1372°C	50°C	IEC584
L	-100°C	+900°C	50°C	DIN 43710
Lr	-200°C	+800°C	50°C	GOST 3044-84
N	-180°C	+1300°C	50°C	IEC584
R	-50°C	+1760°C	100°C	IEC584
S	-50°C	+1760°C	100°C	IEC584
T	-200°C	+400°C	50°C	IEC584
U	-200°C	+600°C	50°C	DIN 43710
W3	0°C	+2300°C	100°C	ASTM E988-90
W5	0°C	+2300°C	100°C	ASTM E988-90

最大偏移量 量程高值的 50%

冷端补偿 $< \pm 1.0^\circ\text{C}$

传感器故障检测 是

传感器故障电流：

检测时 额定 33 μA

其他 0 μA

电压输入：

测量范围 -12...150 mV

最小量程 5 mV

最大偏移量 量程高值的 50%

输入电阻 10 M Ω

输出：

电流输出：

信号范围 4...20 mA

最小信号范围 16 mA

更新时间 440 ms

EEprom 错误时的输出信号 $\leq 3.5 \text{ mA}$

负载电阻 $\leq (\text{V 电源} - 7.2) / 0.023 [\Omega]$

负载稳定性 $< \pm 0.01\%$ 所设量程 / 100 Ω

传感器故障检测：

可设定 3.5...23 mA

Namur NE43 上限 23 mA

Namur NE43 下限 3.5 mA

所设量程 = 当前设定的量程范围

遵守主管机关要求：

EMC	2014/30/EU & UK SI 2016/1091
ATEX	2014/34/EU & UK SI 2016/1107
RoHS.	2011/65/EU & UK SI 2012/3032
EAC.	TR-CU 020/2011
EAC Ex.	TR-CU 012/2011

海洋船舶认证：

DNV · 船舶和近海	TAA0000101
-----------------------	------------

Ex / I.S. 认证：

ATEX：

5334A	DEKRA 20ATEX0096 X
5334B	DEKRA 20ATEX0095 X
IECEX.	DEK 20.0059 X
INMETRO	DEKRA 16.0013 X
EAC Ex.	RU C-DK.HA65.B.00355/19

接线方式

输入：

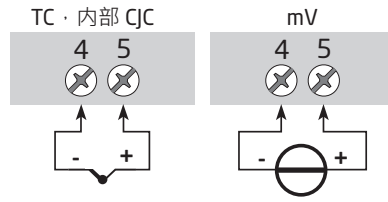

输出：

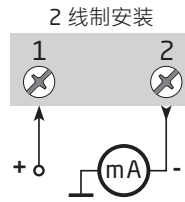

方框图

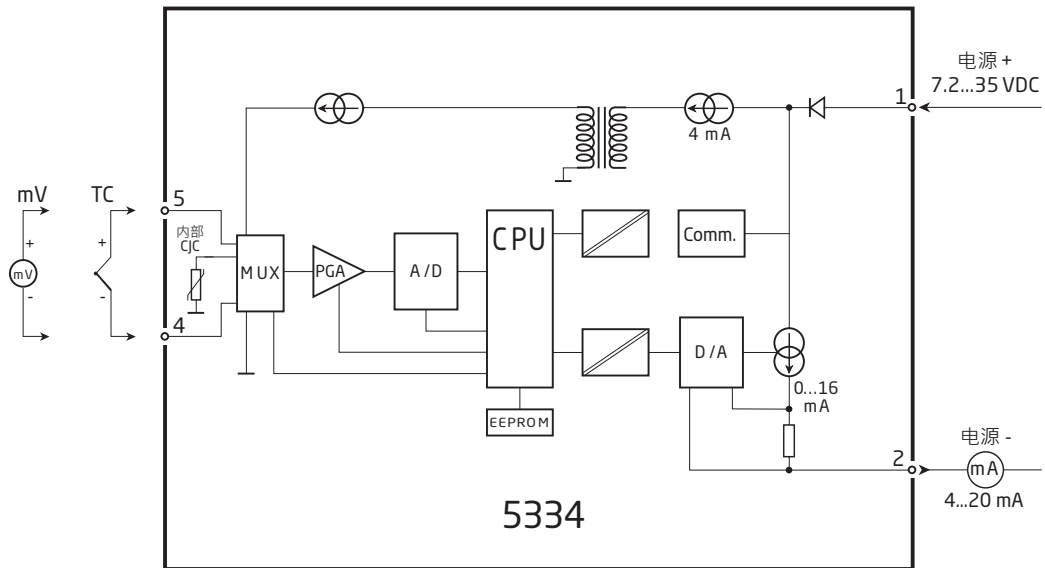

设置参数

- Loop Link 是 5334 配置所需的通信接口。
- 有关配置，请参考下图和 PReset 中的帮助功能。
- Loop link 不允许与安装在危险 (Ex) 区域中的装置进行通信。

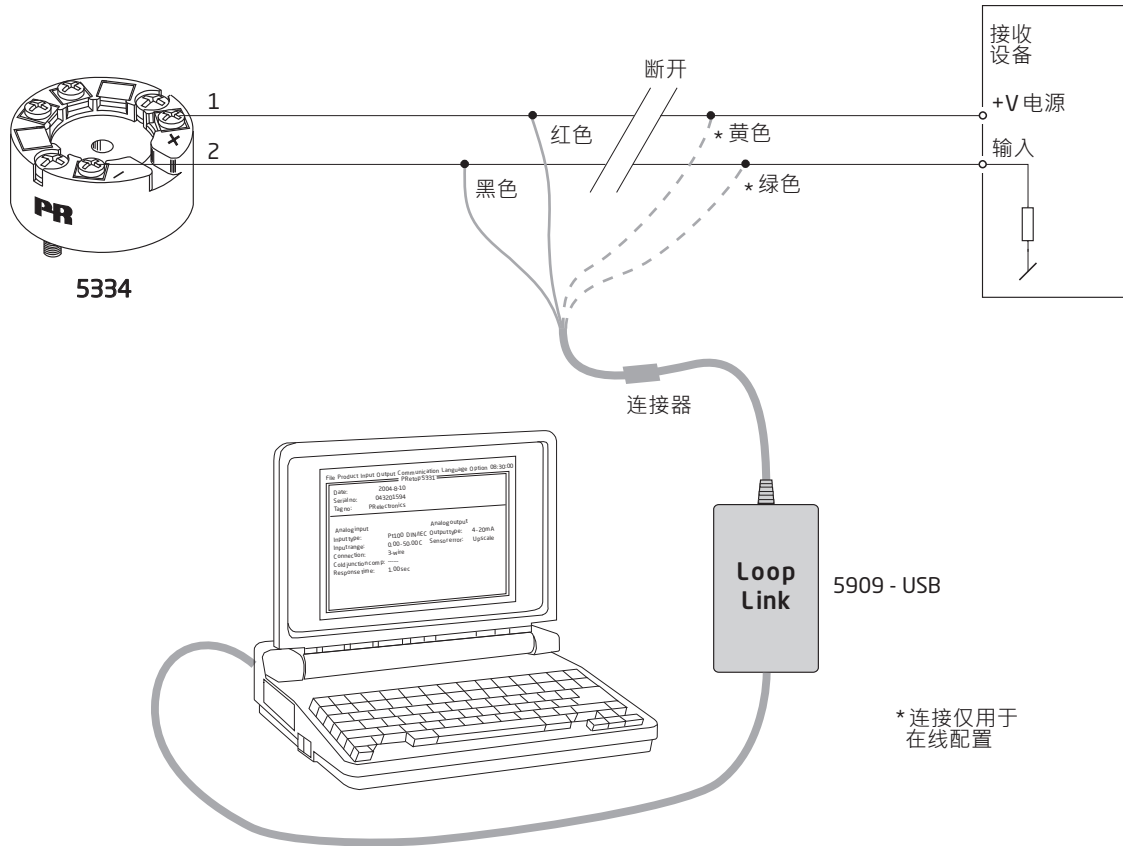

机械规格

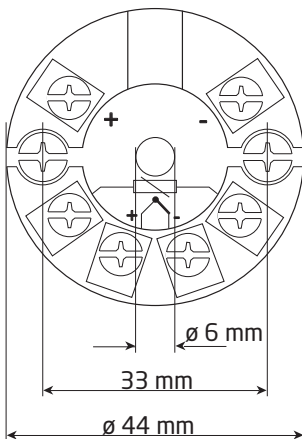

传感器电缆的连接

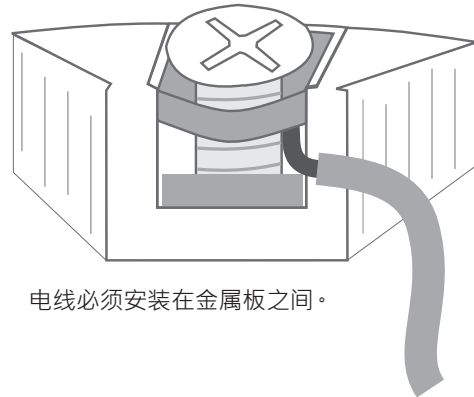

ATEX 安装图 5331QA02-V3R0

为安全安装 5331A 或 5334A，必须遵守以下规定。该模块仅由熟悉适用于该地区国家和国际法律、指令和标准的合格专业人员安装。设备制造年份由序列号的前两位数字指示。

ATEX 认证 DEKRA 20ATEX0096 X

标记牌 II 3 G Ex nA [ic] IIC T6 ... T4 Gc
 II 3 G Ex ec [ic] IIC T6 ... T4 Gc
 II 3 G Ex ic IIC T6 ... T4 Gc
 II 3 D Ex ic IIIC Dc

标准 EN 60079-0: 2018, EN 60079-11: 2012,
 EN 60079-15: 2010, EN 60079-7:2015 +A1: 2018

端子 3,4,5,6	端子 1,2	端子 1,2	端子 1,2
Ex ic IIC, Ex ic IIIC	Ex ic IIC, Ex ic IIIC	Ex ic IIC, Ex ic IIIC	Ex nA, Ex ec
Uo: 9.6 V Io: 25 mA Po: 60 mW Lo: 33 mH Co: 2.4 μ F	Ui = 35 V Ii = 110 mA Ci = 1 nF Li = 10 μ H	Ui = 24 V Ii = 260 mA Ci = 1 nF Li = 10 μ H	Umax ≤ 35 VDC 或 Umax ≤ 24 VDC

Ex ic IIC, Ex ic IIIC 温度等级	环境温度范围	
	Ui=35 V	Ui=24 V
T6	-40°C 至 +54°C	-40°C 至 +63°C
T5	-40°C 至 +69°C	-40°C 至 +78°C
T4	-40°C 至 +85°C	-40°C 至 +85°C

Ex ec, Ex nA 温度等级	环境温度范围	
	Vmax=35 V	Vmax=24 V
T6	-40°C 至 +43°C	-40°C 至 +55°C
T5	-40°C 至 +85°C	-40°C 至 +85°C
T4	-40°C 至 +85°C	-40°C 至 +85°C

安装说明

如果外壳由非金属塑料材料制成，应避免变压器外壳上的静电荷。

如果变压器安装在需要使用设备保护级别 Gc 的爆炸性环境中并应用 Ex ic 保护类型，则变压器应安装在可根据 EN 60529 提供至少 IP20 防护等级的外壳中，并且适合应用并正确安装。

如果变压器安装在需要使用设备保护等级 Dc 的爆炸性环境中，则变压器应安装在单独认证的外壳中，该外壳可根据 EN 60079-0 提供至少 IP5X 的防护等级，并且适合应用并正确安装。外壳的表面温度比环境温度高 +20 K，确定没有灰尘层。

环境温度范围: -40°C 至 +85°C.

如果变压器安装在需要使用设备保护级别 Gc 的爆炸性环境中并应用 Ex nA 或 Ex ec 保护类型，则变压器应安装在单独认证的外壳中，该外壳可根据 EN 60079-0 提供至少 IP54 的防护等级，并且适合应用并正确安装。

如果变压器安装在需要使用设备保护级别 Gc 的爆炸性环境中并应用 Ex nA 或 Ex ec 保护类型，则该设备只能在不超过 EN 60664-1 中定义的污染等级 2 的区域中使用。

ATEX 安装图 5331QA01-V3R0



为安全安装 5331D 或 5334B，必须遵守以下规定。该模块仅由熟悉适用于该地区国家和国际法律、指令和标准的合格专业人员安装。设备制造年份由序列号的前两位数字指示。

ATEX 认证

DEKRA 20ATEX0095 X

标记牌



II 1 G Ex ia IIC T6...T4 Ga

II 2 D Ex ia IIIC Db

I M1 Ex ia I Ma

标准

EN 60079-0: 2018, EN 60079-11: 2012

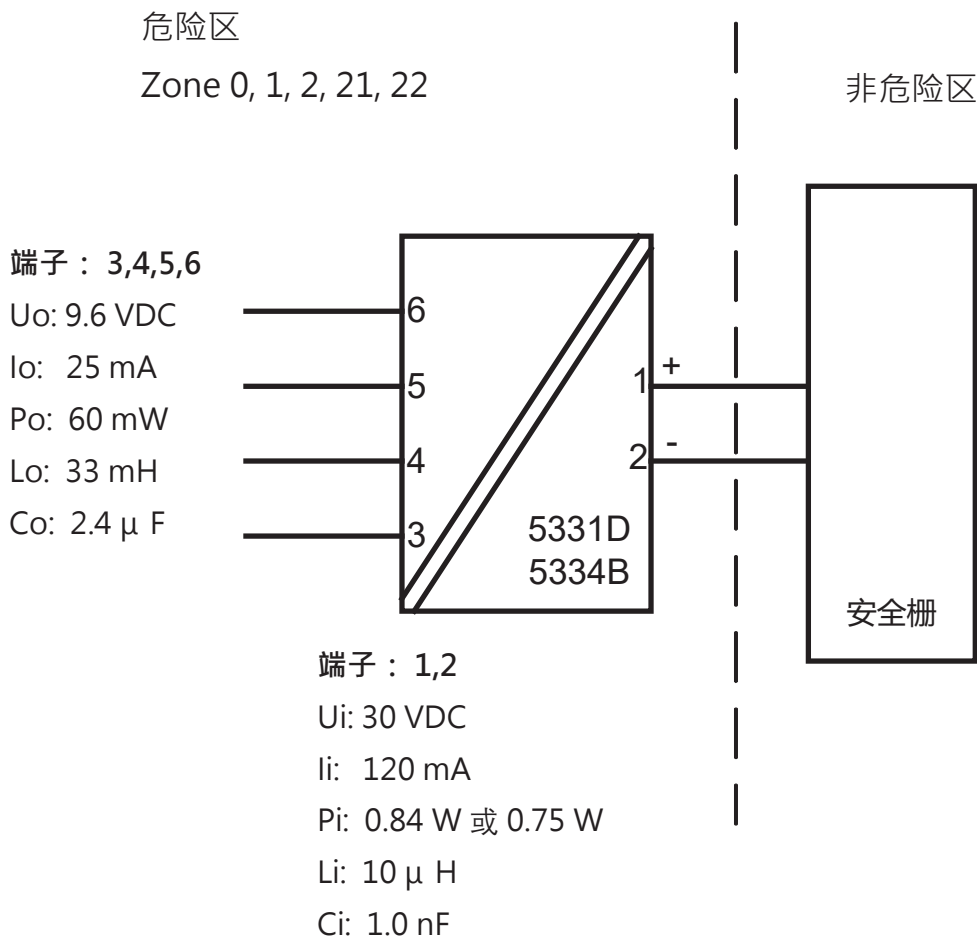

温度等级	环境温度范围	
	Pi: 0.84 W	Pi: 0.75 W
T6	-40°C 至 +47°C	-40°C 至 +50°C
T5	-40°C 至 +62°C	-40°C 至 +65°C
T4	-40°C 至 +85°C	-40°C 至 +85°C

安装说明

如果外壳由非金属塑料材料制成，应避免变送器外壳上的静电荷。

如果变送器安装在需要使用设备保护级别 Ga 的爆炸性环境中，则变送器应安装在可根据 EN 60529 提供至少 IP20 防护等级的外壳中，并且适合应用并正确安装。

如果变送器安装在需要使用设备防护等级 Ga 或 Ma 的爆炸性环境中，并且如果外壳是铝制的，则必须将其安装在能避免因冲击和摩擦火花而形成点火源的位置。

如果变送器安装在需要使用设备保护等级 Db 的爆炸性环境中，则变送器应安装在单独认证的外壳中，该外壳可根据 EN 60079-0 提供至少 IP5X 的防护等级，并且适合应用并正确安装。外壳的表面温度比环境温度高 +20 K，确定没有灰尘层。

环境温度范围: -40°C 至 +85°C.

如果变送器安装在需要使用设备保护等级 Ma 的爆炸性环境中，则变送器应安装在可根据 EN 60529 提供至少 IP54 防护等级的外壳中，并且适合应用并正确安装。

环境温度范围: -40°C 至 +85°C.

应使用适用于相关应用和正确安装的电缆封口和堵封件。

若环境温度 $\geq 60^\circ\text{C}$ ，则应使用耐热电缆，其额定耐热温度至少应比环境温度高出 20 K。

传感器电路与输入电路并非绝对电气隔离。然而，电路间的电气隔离能够承受 1 分钟交流 500V 的测试电压。

IECEx-installation drawing 5331QI02-V2R0

For safe installation of 5331A and 5334A the following must be observed. The module shall only be installed by qualified personnel who are familiar with the national and international laws, directives and standards that apply to this area. Year of manufacture can be taken from the first two digits in the serial number.

Certificate IECEx DEK 20.0059X

Marking Ex nA [ic] IIC T6 ... T4 Gc
Ex ec [ic] IIC T6 ... T4 Gc
Ex ic IIC T6 ... T4 Gc
Ex ic IIIC Dc

Standards IEC 60079-0: 2017, IEC 60079-11: 2011,
IEC 60079-15: 2010, IEC 60079-7:2017

Terminal 3,4,5,6	Terminal 1,2	Terminal 1,2	Terminal 1,2
Ex ic IIC, Ex ic IIIC	Ex ic IIC, Ex ic IIIC	Ex ic IIC, Ex ic IIIC	Ex nA, Ex ec
Uo: 9.6 V Io: 25 mA Po: 60 mW Lo: 33 mH Co: 2.4 μ F	Ui = 35 V Ii = 110 mA Ci = 1 nF Li = 10 μ H	Ui = 24 V Ii = 260 mA Ci = 1 nF Li = 10 μ H	Umax \leq 35 VDC or Umax \leq 24 VDC

Ex ic IIC, Ex ic IIIC Temperature Class	Ambient temperature range	
	Ui=35 V	Ui=24 V
T6	-40°C to +54°C	-40°C to +63°C
T5	-40°C to +69°C	-40°C to +78°C
T4	-40°C to +85°C	-40°C to +85°C

Ex ec, Ex nA Temperature Class	Ambient temperature range	
	Vmax=35 V	Vmax=24 V
T6	-40°C to +43°C	-40°C to +55°C
T5	-40°C to +85°C	-40°C to +85°C
T4	-40°C to +85°C	-40°C to +85°C

Installation notes

If the enclosure is made of non-metallic plastic materials, electrostatic charges on the transmitter enclosure shall be avoided.

If the transmitter is installed in an explosive atmosphere requiring the use of equipment protection level Gc and applied in type of protection Ex ic, the transmitter shall be mounted in an enclosure that provides a degree of protection of at least IP20 according to IEC 60529, and that is suitable for the application and correctly installed.

If the transmitter is installed in an explosive atmosphere requiring the use of equipment protection level Dc, the transmitter shall be mounted in a separately certified enclosure that provides a degree of protection of at least IP5X according to IEC 60079-0, and that is suitable for the application and correctly installed. The surface temperature of the outer enclosure is +20 K above the ambient temperature, determined without a dust layer.
Ambient temperature range: -40°C to +85°C.

If the transmitter is installed in an explosive atmosphere requiring the use of equipment protection level Gc and applied in type of protection Ex nA or Ex ec, the transmitter shall be mounted in a separately certified enclosure that provides a degree of protection of at least IP54 according to IEC 60079-0, and that is suitable for the application and correctly installed.

If the transmitter is installed in an explosive atmosphere requiring the use of equipment protection level Gc and applied in type of protection Ex nA or Ex ec, the equipment shall only be used in an area of not more than pollution degree 2, as defined in IEC 60664-1.

IECEX-installation drawing 5331QI01-V2R0



For safe installation of 5331D or 5334B the following must be observed. The module shall only be installed by qualified personnel who are familiar with the national and international laws, directives and standards that apply to this area. Year of manufacture can be taken from the first two digits in the serial number.

Certificate	IECEX DEK 20.0059X
Marking	Ex ia IIC T6...T4 Ga Ex ia IIIC Db Ex ia I Ma
Standards	IEC 60079-0: 2017, IEC 60079-11: 2011



Temperature Class	Ambient temperature range	
	Pi: 0.84 W	Pi: 0.75 W
T6	-40°C to +47°C	-40°C to +50°C
T5	-40°C to +62°C	-40°C to +65°C
T4	-40°C to +85°C	-40°C to +85°C

Installation notes

If the enclosure is made of non-metallic plastic materials, electrostatic charges on the transmitter enclosure shall be avoided.

If the transmitter is installed in an explosive atmosphere requiring the use of equipment protection level Ga, the transmitter shall be mounted in an enclosure that provides a degree of protection of at least IP20 according to IEC 60529, and that is suitable for the application and correctly installed.

If the transmitter is installed in an explosive atmosphere requiring the use of equipment protection level Ga or Ma, and if the enclosure is made of aluminum, it must be installed such, that ignition sources due to impact and friction sparks are excluded.

If the transmitter is installed in an explosive atmosphere requiring the use of equipment protection level Db, the transmitter shall be mounted in a separately certified enclosure that provides a degree of protection of at least IP5X according to IEC 60079-0, and that is suitable for the application and correctly installed. The surface temperature of the outer enclosure is +20 K above the ambient temperature, determined without a dust layer.
Ambient temperature range: -40°C to +85°C.

If the transmitter is installed in an explosive atmosphere requiring the use of equipment protection level Ma, the transmitter shall be mounted in an enclosure that provides a degree of protection of at least IP54 according to IEC 60529, and that is suitable for the application and correctly installed.
Ambient temperature range: -40°C to +85°C.

Cable entries and blanking elements shall be used that are suitable for the application and correctly installed.

For an ambient temperature $\geq 60^\circ\text{C}$, heat resistant cables shall be used with a rating of at least 20 K above the ambient temperature.

The sensor circuit is not infallibly galvanically isolated from the input circuit. However, the galvanic isolation between the circuits is capable of withstanding a test voltage of 500 VAC for 1 minute.

Desenho de Instalação INMETRO



Para instalação segura do 5331A ou 5334A o seguinte deve ser observado. O modelo deve apenas ser instalado por pessoas qualificadas que são familiarizadas com as leis nacionais e internacionais, diretrizes e padrões que se aplicam a esta área.

O ano de fabricação pode ser pego dos dois primeiros dígitos do número de série.

Certificado DEKRA 16.0013 X

Marcas
 Ex nA [ic] IIC T4..T6 Gc
 Ex ic IIC T4..T6 Gc
 Ex ic IIIC Dc

Normas ABNT NBR IEC 60079-0 : 2013; ABNT NBR IEC 60079-11 : 2013
 ABNT NBR IEC60079-15 : 2012

T4: $-40 \leq T_a \leq 85^\circ\text{C}$
 T6: $-40 \leq T_a \leq 60^\circ\text{C}$

Terminais:

3,4,5,6

Uo: 9,6 V
 Io: 25 mA
 Po: 60 mW
 Lo: 33 mH
 Co: 2,4 μF

Terminais: 1,2

Ex nA

$U \leq 35 \text{ VDC}$

Terminais: 1,2

Ex ic

$U_i = 35 \text{ VDC}$
 $I_i = 110 \text{ mA}$
 $L_i = 10 \mu\text{H}$
 $C_i = 1,0 \text{ nF}$

Notas para instalação

Para a instalação em uma atmosfera de gás potencialmente explosivo, aplicam-se as instruções a seguir:

Para a instalação nA o transmissor deve ser instalado em um invólucro de metal, por exemplo, gabinete em forma B que forneça um grau de proteção de pelo menos IP54 de acordo com ABNT NBR IEC60529 ou em um invólucro com tipo de proteção Ex n ou Ex e.

Para a instalação Ex ic o transmissor deve ser instalado em um invólucro proporcionando um grau de proteção IP20 de acordo com a norma ABNT NBR IEC60529. E o invólucro deve, pelo menos, ser adequado para a aplicação e corretamente instalado.

Dispositivos de entrada de cabos e elementos de supressão devem cumprir os mesmos requisitos.

Para temperatura ambiente $\geq 60^\circ\text{C}$, fios de resistência ao calor devem ser usados com uma faixa de pelo menos 20K acima da temperatura ambiente.

Para a instalação em uma atmosfera de poeira potencialmente explosiva, aplicam-se as instruções a seguir:

O transmissor deve ser montado em invólucro de metal forma B de acordo com DIN43729 que está fornecendo pelo menos um grau de proteção IP6X de acordo com ABNT NBR IEC60529.

O invólucro deve ser adequado para aplicação e instalado corretamente.

As entradas dos cabos e os elementos de obturação que podem ser utilizados devem ser adequados à aplicação pretendida e corretamente instalados.

A temperatura da superfície do invólucro é igual à temperatura ambiente mais 20 K, para uma camada de pó, com uma espessura de até 5 mm.

Desenho de Instalação INMETRO



Para instalação segura do 5331D ou 5334B o seguinte deve ser observado. O modelo deve apenas ser instalado por pessoas qualificadas que são familiarizadas com as leis nacionais e internacionais, diretrizes e padrões que se aplicam a esta área.
O ano de fabricação pode ser pego dos dois primeiros dígitos do número de série.

CertificadoDEKRA 16.0013 X

Marcas
Ex ia IIC T6...T4 Ga
Ex ia IIIC Da
Ex ia I Ma

Normas ABNT NBR IEC 60079-0: 2013; ABNT NBR IEC 60079-11: 2013

Áreas classificadas

Zona 0, 1, 2, 20, 21, 22,

T4: $-40 \leq T_a \leq 85^\circ\text{C}$

T5: $-40 \leq T_a \leq 60^\circ\text{C}$

T6: $-40 \leq T_a \leq 45^\circ\text{C}$

Terminais 3,4,5,6

Uo: 9,6 VDC

Io: 25 mA

Po: 60 mW

Lo: 33 mH

Co: 2,4µF

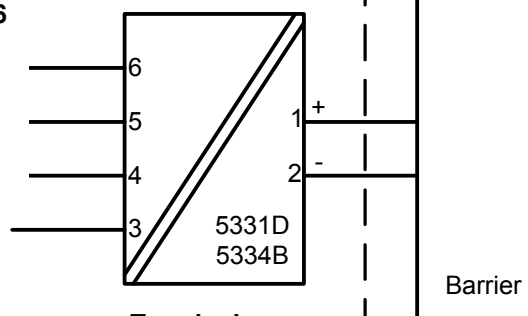

Terminais:

1,2

Ui: 30 VDC

Ii: 120 mA

Pi: 0,84 W

Li: 10µH

Ci: 1,0nF

Notas de instalação

O circuito do sensor não é isolado galvanicamente do circuito de entrada de forma infalível. Contudo, a isolamento galvânica entre os circuitos é capaz de resistir a um ensaio de tensão de 500Vac durante 1 minuto.

Em uma atmosfera de gás potencialmente explosiva, o transmissor deve ser montado em um invólucro a fim de garantir um grau de proteção de no mínimo IP20 de acordo com a ABNT NBR IEC60529. Se contudo, o ambiente necessitar de um nível de proteção maior, isso deve ser levado em consideração.

Se o transmissor é instalado em uma atmosfera explosiva exigindo o uso de equipamento de proteção de nível Ga e se o invólucro é feito de alumínio, ele deve ser instalado de modo que, mesmo em caso remoto de avaria, fontes de ignição devido ao impacto e fricção, faíscas são eliminadas.

Se o invólucro é feito de materiais não metálicos, cargas eletroestáticas devem ser evitadas.

Para instalação em atmosfera de poeira potencialmente explosiva, as instruções a seguir são aplicáveis:

O transmissor deve ser montado em invólucro de metal forma B de acordo com DIN43729 que está fornecendo um grau de proteção de pelo menos IP6X de acordo com ABNT NBR IEC60529. O invólucro deve ser adequado para aplicação pretendida e instalado corretamente.

As entradas dos cabos e os elementos de obturação que podem ser utilizados devem ser adequados à aplicação pretendida e corretamente instalados.

Para temperatura ambiente $\geq 60^{\circ}\text{C}$, fios de resistência ao calor devem ser usados com uma faixa de pelo menos 20K acima da temperatura ambiente.

A temperatura da superfície do invólucro é igual à temperatura ambiente mais 20 K, por uma camada de pó, com espessura de até 5 mm.

文档更新记录

以下列表提供了有关本文档修订的说明。

版本号	日期	说明
108	1345	添加 IECEx 和 INMETRO 认证。
109	1514	添加 PESO/CCOE 认证。 GOST 认证替换为 EAC 认证。
110	1707	更新 INMETRO 安装图。
111	2004	添加 PESO/CCOE 认证中断。 更新 INMETRO 安装图。
112	2145	ATEX和IECEX认证已更新 - Ex na 更改为 Ex ec。
113	2245	添加了 UKCA。

无论您身在何处， 我们始终在您身边

无论您身在何处，都将获得我们标志性红色模块的全力支持

我们所有的设备都提供权威的专家服务，且享受长达五年的质量保证。您购买的每款产品都将获得个性化的技术支持和指导，按时交货，保修期内免费维修，丰富的技术文档等服务。

我们的总部在丹麦，我们在世界各地设有办事处并在全球创建授权合作伙伴关系。我们能在全球范围内为您提供本地化

服务。这意味着我们总是伴随在您身边，并且非常了解当地市场。

我们致力于打造高客户满意度产品，并将 PERFORMANCE MADE SMARTER 这一理念传向世界。

了解更多有关我们的保修计划，或想与您所在地区的销售代表会面，请访问 prelectronics.com。

让 PERFORMANCE MADE SMARTER 助您一臂之力

PR electronics 是一家行业领先的、专注于使过程控制更加安全、可靠和高效的技术型公司。自 1974 年以来，我们一直致力于高精度-低功耗型核心技术的开发。秉承这种精神，我们不断地为产品设置新的标准，如此这般才能够在客户的过程测量点与其过程控制系统之间进行通信、监控和连接。

我们的创新专利技术来源于大量的研发设施以及对客户需求和工艺过程的深刻理解。简约、专注、勇气、卓越是我们的座右铭。这指引着我们不断帮助一些世界上最大的公司实现更卓越的智能化 (PERFORMANCE MADE SMARTER)。